

Num. parte	Material	Weight	A°	R	Hr	Hv
85°-R08	1.0503 (C45)	36.099	85°	0,8	145	145,38

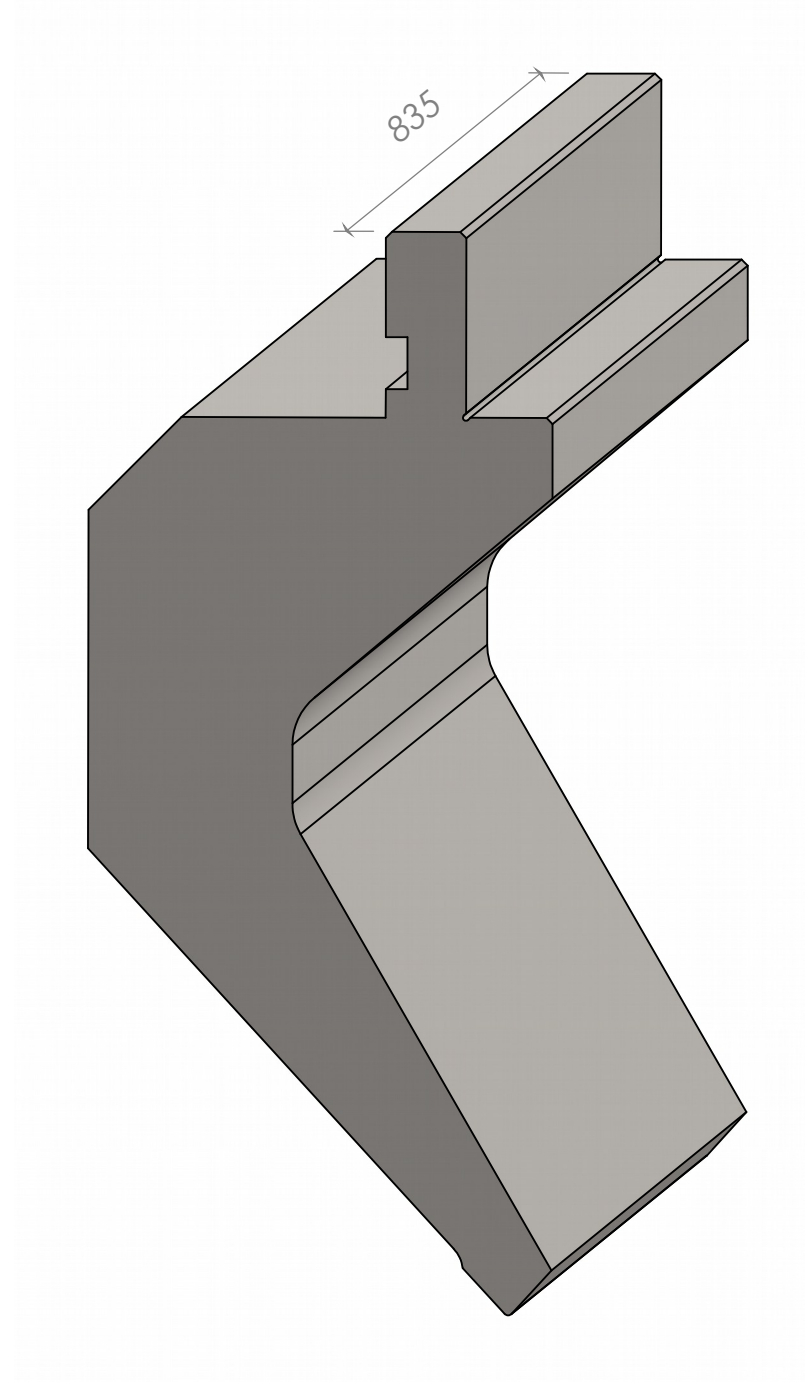
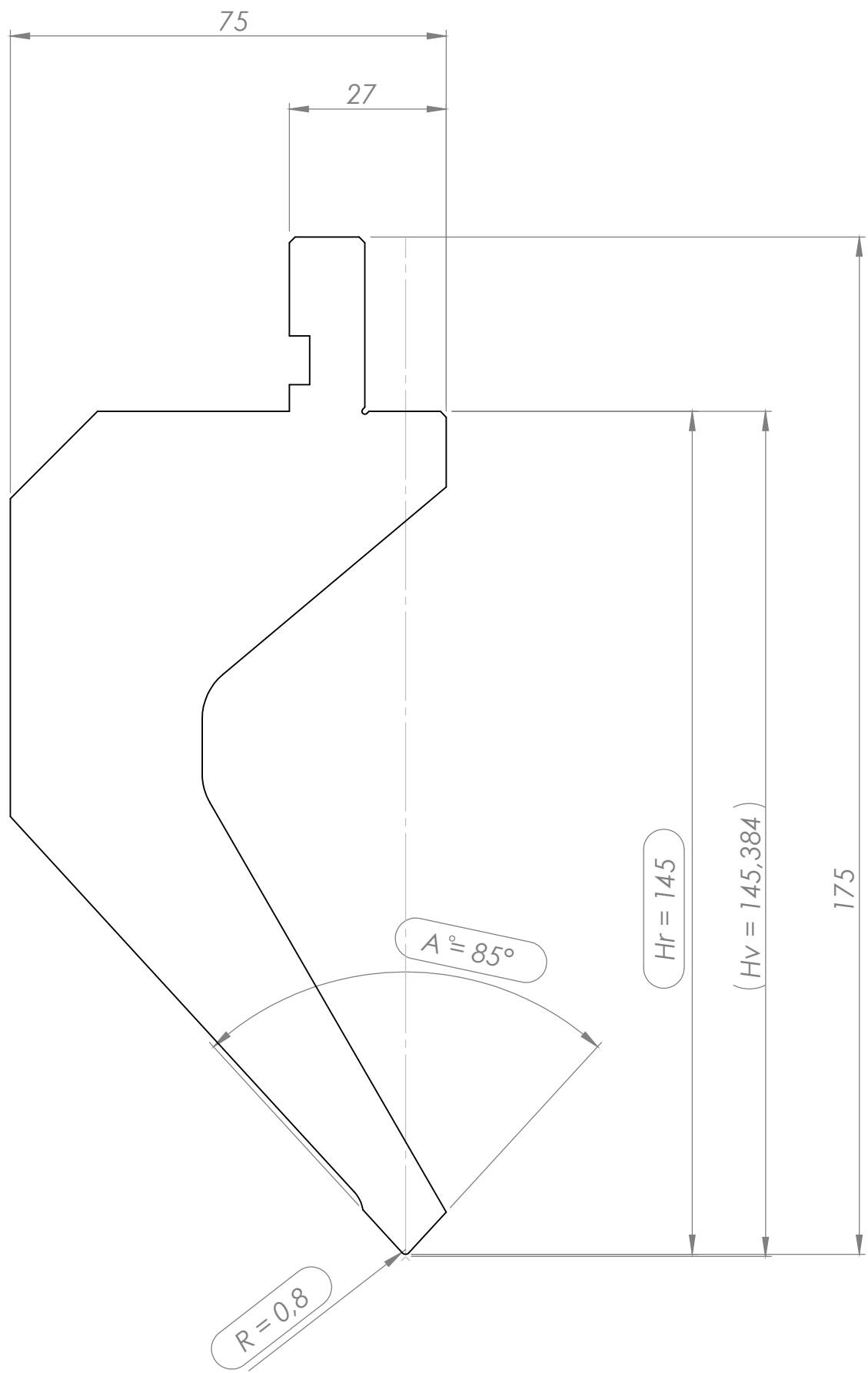

MAX LOAD : 500 kN/m

PUNZONE SERIE PS 1027

TRATTAMENTO TERMICO
Temprato a Induzione HRC 52-58