

Num. Parte	Materiale	Peso	A°	R	Hr	Hv
75°-R08	1.0503 (C45)	26,361	75°	0,8	120	120,51
88°-R02	1.0503 (C45)	26,001	88°	0,2	119,9	119,99

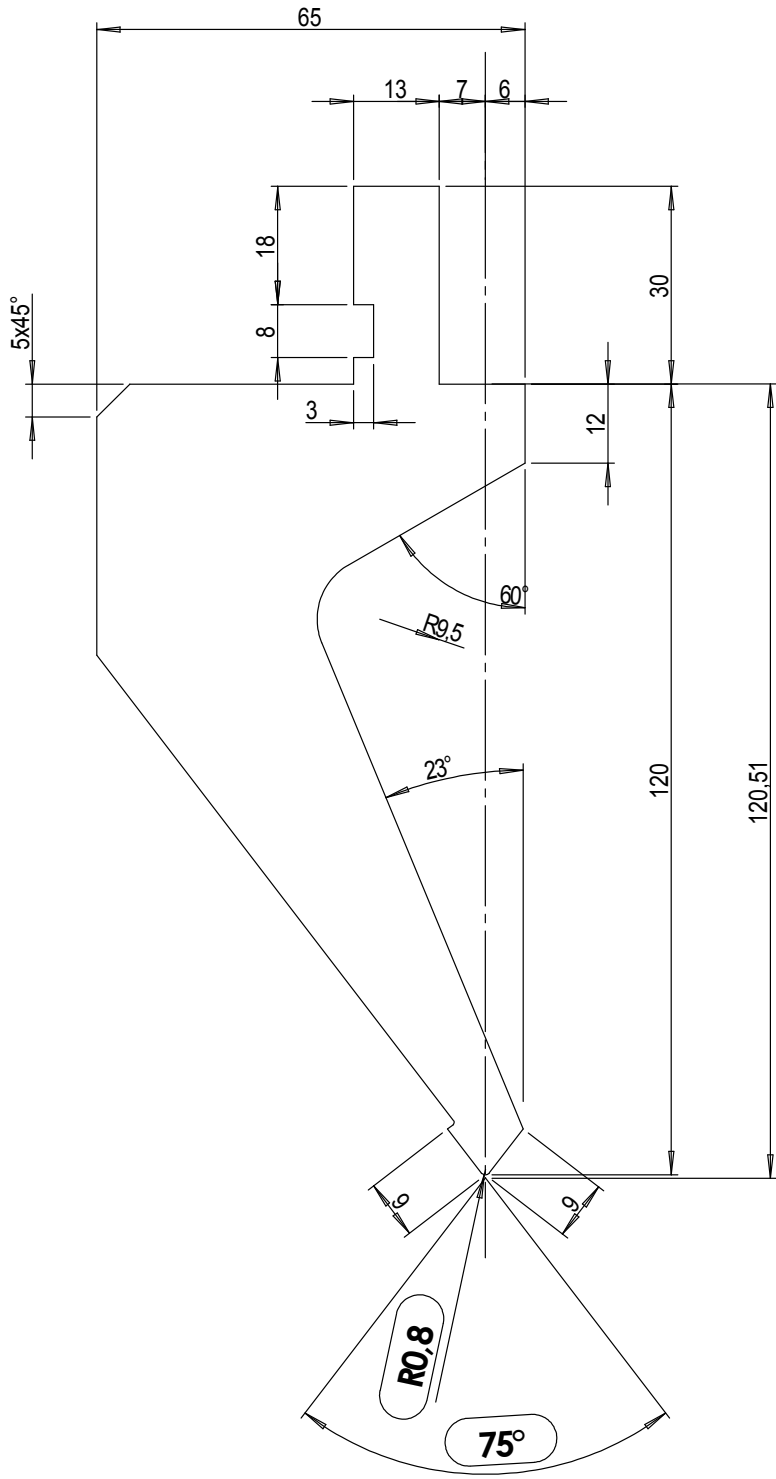

PS 1020 75°-R08

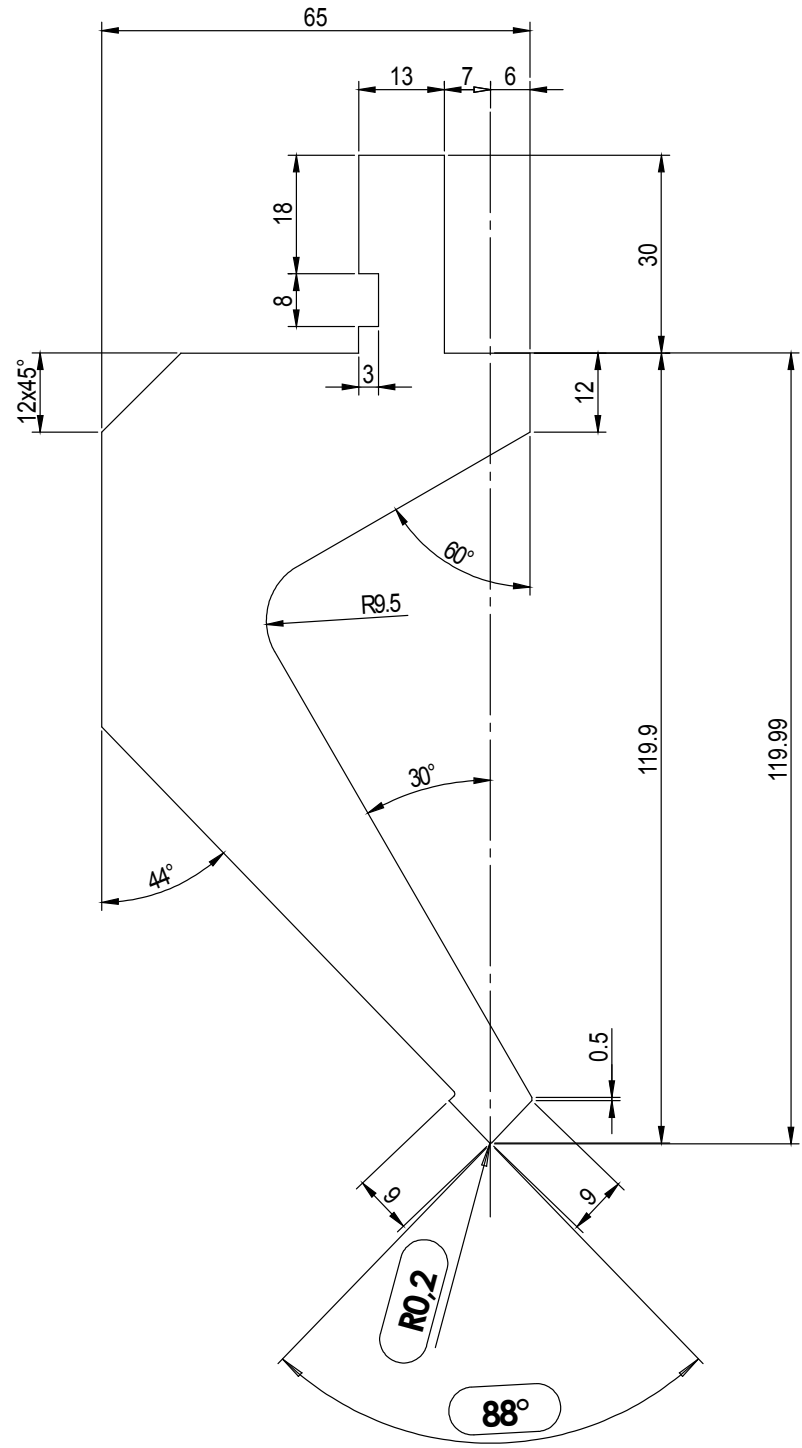

PS 1020 88°-R02

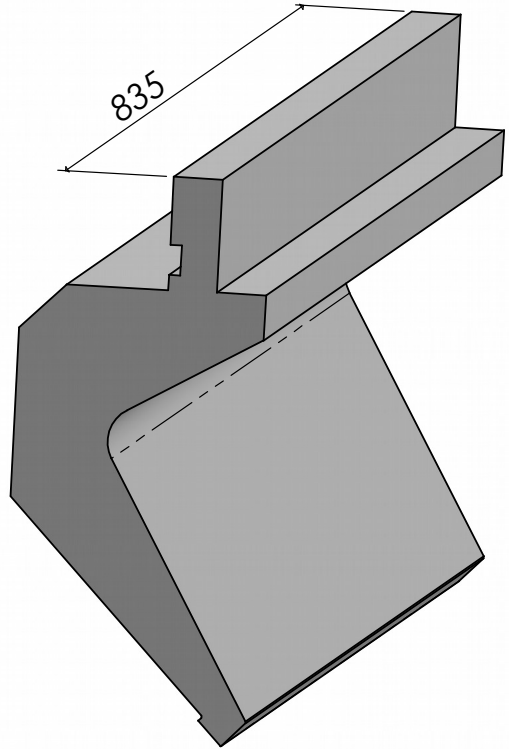
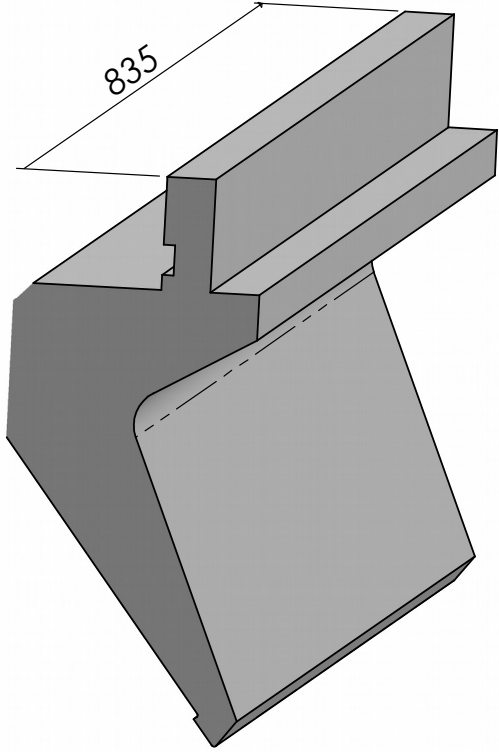

PUNZONE SERIE PS 1020
 MAX LOAD: 490 kN/m
 Temprato a Induzione 52-58 HRC